

6241 Bellows Footswitch/Palm Switch

Multi-pedal version

herga

Technology Ltd

- Multi-pedal footswitch, 1-8 pedal options
- Compact for discrete placement beneath equipment, or for storage
- Robust but aesthetic design
- Soft touch buttons with a light operating force
- Ideal for motion control applications

CE [®] **UL** **US**



Reference dimensions

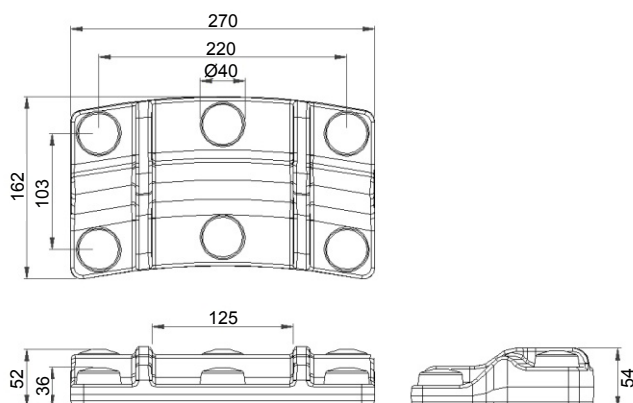

General specifications

Standards/approvals	UL 60601-1 File No. E 207181, IEC 60601-1
Degree of protection	EN 60529 IP67 (IP68 upon request)
Connection method	Stripped cable cores or connector of your choice, straight or curly coil cable
Electrical rating	50mA 24V DC
Contact configuration	SPST N/O

Operating temperature range	+10°C to +50°C
Body material	Thermoplastic
Weight	1.0 kg
Additional information	choice of colours, logos and labels available